

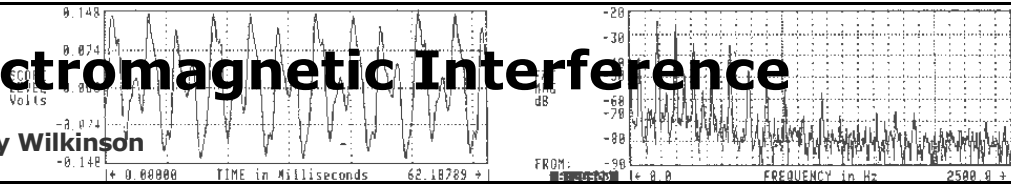

Electromagnetic Interference

by Tony Wilkinson



This article is intended to give a rough guide to avoiding problems associated with electromagnetic interference by giving some insight into what's going on. Those of you with a knowledge of electronics may well cringe at some of the generalisations but, please, bear with me !

The term ElectroMagnetic Interference (EMI) covers all the ways in which unwanted 'noise' can get into (and out of) electrical systems. On the whole, it is really quite complicated - many engineers are employed just to test and qualify equipment to ElectroMagnetic Compatibility (EMC) regulations - preventing systems radiating too much interference and, at the same time, being immune to external influences. Companies involved in manufacturing electronics can spend untold amounts of cash on EMC training and consultancy (e.g.: www.yorkemc.co.uk/training).

Happily, we're going to simplify this quite a bit...

We're going to concentrate on electrical 'noise' which can travel through the air - Radio Frequency Interference (RFI).



This can be generated whenever an electric current is switched quickly - an old hair drier motor can generate RFI as the brushes in the motor switch current in the motor coils whereas a radio transmitter may purposefully alternate current very quickly to generate the RF signal sent to the antenna.

In fact, the earliest radios used high-voltage sparks to generate RF signal.

Here's Marconi in 1896 with a Spark Gap transmitter set which could send and receive Morse Code.

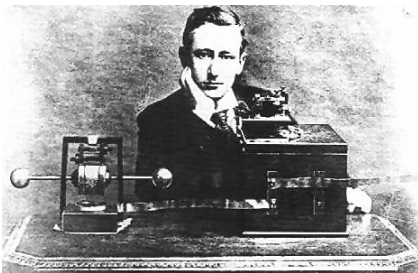

In our case, one of the main culprits generating RFI is the ignition / 'magneto' system on the engine.



We can think of our source of interference as a radio transmitter and compare it to an actual radio.

A hand-held transmitter just sends radio waves straight out of the antenna on the top, but if we consider a transceiver set installed in some Air Traffic Control tower it is a bit different...

The RF signal doesn't escape straight away... it is contained within a coax cable

which takes it up to the antenna on the roof.

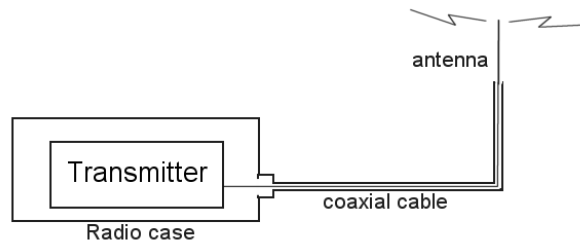

Now, don't be fooled into thinking that the antenna does anything very special - it is really just a hole in the end of the coax cable (roughly speaking, stripping back a couple of feet of a coax cable and leaving the inner wire poking out will do the same job as an expensive antenna - it just lets the RF escape).

This, in a round-about way, introduces our best weapon in our EMI armoury: we can 'box-in' RF signals by enclosing them in anything electrically-conducting. This is known as the Faraday Cage.

If you make a big cage from chicken wire and make sure all the edges make contact, your hand-held transceiver wouldn't seem to work inside because the RF couldn't get out.



Furthermore, you wouldn't be able to receive anything because no RF could get in.

In the case of our ATC transmitter, the complete 'cage' is the radio case *plus* the whole length of the coaxial cable which surrounds the RF wire with a conductive shield (including through the coax plug and socket).

Another way of envisaging this is to compare it with a tank of water with a hose pipe connected. Assuming there's no leaks, the water only comes out of the end of the pipe. So, we can stop RF escaping by enclosing the source of the signal within a conductive shield. Any gaps in the shielding

International AUTOGYRO 1/4ly magazine.

Contains News, Diary, Features, Free Ads (even if you are not a subscriber), Event reports, Gyro Modeller's, Gyro registrations. Four issues per year, averaging between 40 and 50 A4 size pages per issue.

UK subscription currently £10 incl postage, Overseas £15 or US\$20 (this will increase to £12.50 / US\$25 or £20 from June 1st). Cheques acceptable if drawn on a UK bank, payable to R. Bartlett please, or cash.

R. Bartlett, 9, Layton Road, Parkstone, POOLE, Dorset BH12 2BH, UK.

(Continued from page 21)

may let RF escape—like putting a hole in our water tank or hosepipe.

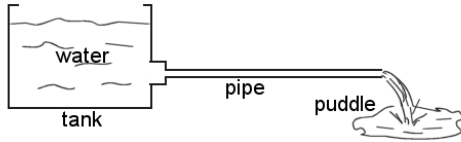

But this is only half the problem... since it is often not practical to perfectly 'seal in' unwanted RF noise we need to be able to protect sensitive equipment from RF noise which has escaped.

Luckily, the solution is exactly the same!

As I mentioned earlier, a hand-held transceiver can't receive signals if it is enclosed in a Faraday Cage. We can stretch our analogy with tanks of water and imagine us trying to 'receive' water inside a submarine. The water (like external radio waves) is all around, but it can't get in.

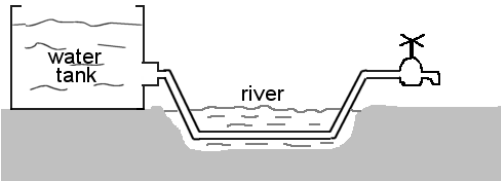

Similarly, a pipe running beneath a river won't let river water in unless there's a hole in the pipe.

When our ATC transceiver is listening, the sensitive radio receiver only hears signals 'let in' at the antenna, the shielded cable prevents any other electrical noise getting in along its length.

So... where does this get us ?

Shielding equipment and cables can stop RFI being emitted and stop noise being received.

Any gaps in the shielding can let RF in or out—this is an important point to remember, a hole in a Faraday Cage is like a hole in a water tank. A gap in a coaxial shield is like a gap in a hosepipe, never mind that most of the pipe is OK, it's the 1/2" gap that lets all the water out !

Practicalities

Shielding electrical equipment means putting it in a sealed box and using cable with a conductive shield (e.g. coax) - making sure that the shield is connected to earth and making sure there's good continuity of the shielding where cables enter and leave enclosures.

Things you *know* to be radiating electrical noise (like magneto switch wires), you try to enclose them to stop 'em radiating. In the same way, things you *know* to be sensitive (like intercom wiring) you try to stop noise getting in.

Keeping 'noisy stuff' as far as possible from 'sensitive stuff' is also good practice (since, I've mentioned, it is rare that shielding is 100% effective).

Magneto switch wiring is likely to be a major source of noise for radio and intercoms so it is essential to use good coax cable for these.

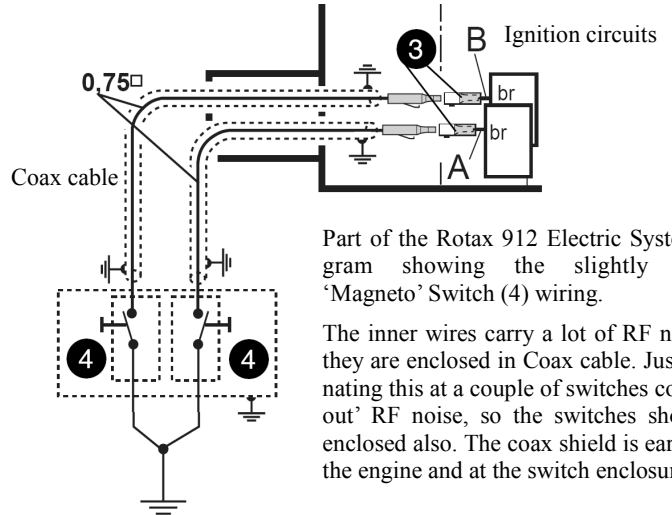

Part of the Rotax 912 Electric System diagram showing the slightly cryptic 'Magneto' Switch (4) wiring.

The inner wires carry a lot of RF noise, so they are enclosed in Coax cable. Just terminating this at a couple of switches could 'let out' RF noise, so the switches should be enclosed also. The coax shield is earthed on the engine and at the switch enclosure.

A simplified view of the above shows what we are trying to achieve: complete electrical enclosure of the ignition circuit wires.

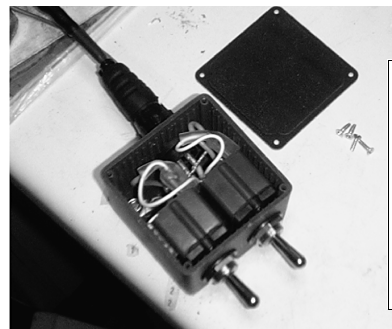
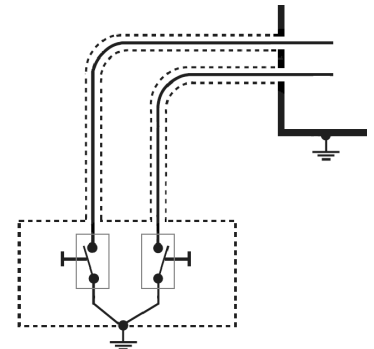

Practical implementation: 'Magneto' switches built into a small conductive-coated plastic box with the coax leads coming in through a connector at the rear.

Also, on transceiver installations, don't forget that the radio intentionally emits very strong RF, so make sure you have a good coax connection to the antenna with an adequate ground plane connected to ground (the airframe) and use audio coax for wiring up the headphones, mikes and PTT.

That's about all I have space for in this issue—hope it's made some sort of sense !

Next time we'll look at 'supply noise' and 'ground loops' which are conducted rather than radiated forms of interference.

Tony Wilk

mail@tonywilk.co.uk

Follow the growth of the latest web Portal. Whatever your Interests in Autogyros, **this Portal is for you.**

www.gyropilot.com